

Science, Technology, Engineering, and Management of Risk of Refineries, Oilsands Operations, and Facilities

Why STEM_Risk Refienry™

- Is an effective and economical tool to control corrosion and related degradations in refineries, oilsands operations, and facilities.
- It analyzes various materials, various environmental conditions, and various mechanisms by which corrosion and degradations taking place in refineries, oilsands operations, and facilities
 - Considers more than 95 damage mechanisms
- It helps to develop various documents, diagrams, and best practices required to control corrosion and degradation including:
 - Corrosion Control Document (CCD)
 - Corrosion Loops (CL)
 - Process-Flow Diagram (PFD)
 - Materials Selection Diagram (MSD)
 - Integrity Operating Windows (IOW)
 - Risk-Based Inspection (RBI).

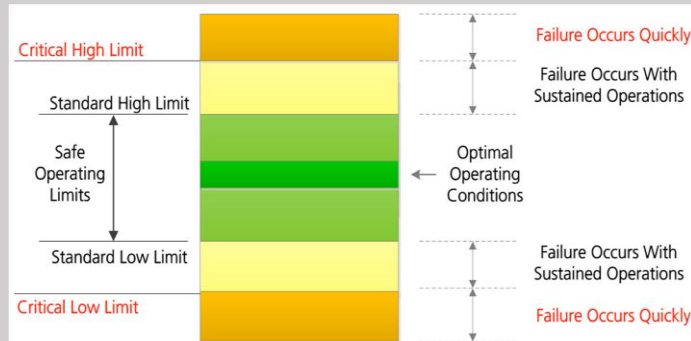
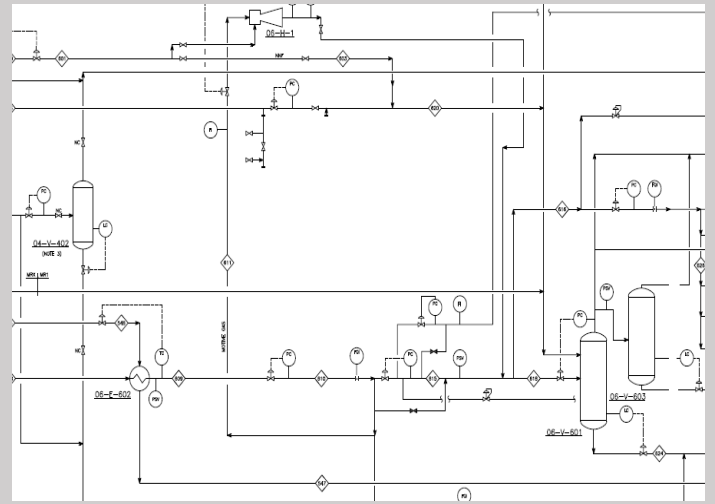

STEM_Risk_Refinery™ Uniqueness

- Applicable to refineries, oilsands operation, and facilities
- Identifies materials used in various operations
- Determines damage mechanisms (DM)
 - Corrosion rate and degradation rate
- Establishes Corrosion Monitoring Locations (CML)

For more details

Web: www.STEMCorrosion.com | Phone: 403-991-4036 | Email: office@cormagnet.com

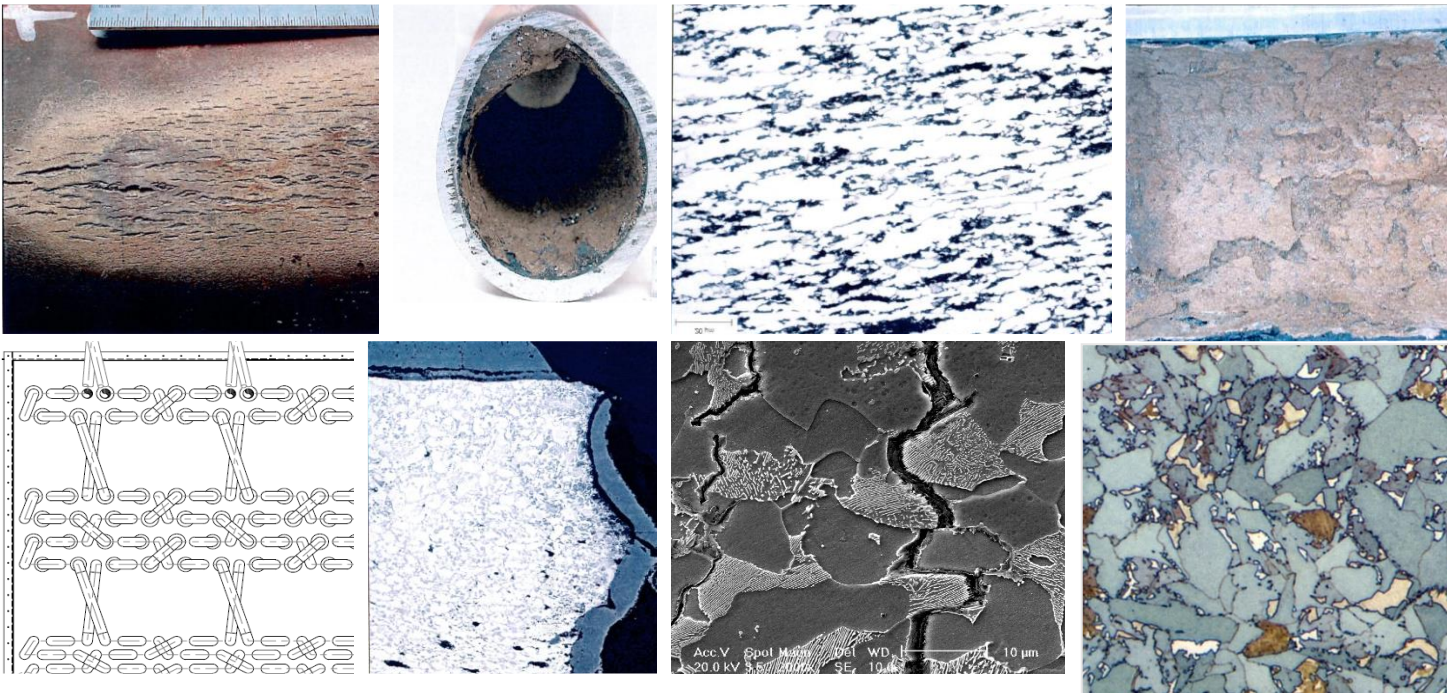

STEM_Risk_Refinery™ Based on

- American Petroleum Institute (API) 571, “Damage Mechanisms Affecting Fixed Equipment in the Refining Industry”
- API 581, “Risk Based Inspection Technology”
- API 584, “Integrity Operating Windows”
- Subject Matter Experts (SME) knowledge on 95 Damage Mechanisms.



Services Offered

- Format the input data from the client, run inhouse STEM_Risk_Refinery™, analyse data, and provide results to the client.
- Determination of damage mechanisms (DM) occurring in given operating conditions
- Calculation of corrosion rate (CR) or degradation rate (DR) considering various DM
- Development of Corrosion Loops (CL)
- Development of Corrosion Control Diagrams (CCD)
- Establishment of Corrosion Monitoring Locations (CML)
- Creation of Integrity Operating Windows (IOW)
- Technical consultation and More!